

CART SERIES

TASK / INSPECTION / HAZARDOUS

DATE: _____ PROJECT MGR: _____

JOB: _____

PN: _____



4 Ft. Single Fixture Cart

APPLICATIONS

Task Areas
General Industrial
Portable Inspection Areas

2 WHEEL VERTICAL CART: P/N 4346
8" semi-pneumatic ball bearing wheels
20' power cord with a 3 prong 120 Volt 15 amp plug
or 277 Volt 15 amp plug available. Must specify.
NEMA rated power cord plugs other than specified can be provided.

The single fixture light cart is designed to provide portable lighting solutions for applications ranging from inspection to laboratory and general industrial task lighting. Light fixture options allow you to customize your cart to fit your work application requirements. Some assembly required. Lamps included.

SPECIFICATIONS

FIXTURE LISTINGS: ETL listed. U.S. and Canada
INS: Non-Hazardous
H: Class I and II Division 2
I: UL 1598 ONLY



ELECTRICAL: Available in 32 watt with T8 lamps
Voltage: 120 volts or 277 volts
Hazardous location carts 120 volts only

OPTIONS:

CART OPTIONS
Shelf trays: 20 1/2" W x 8" D x 3" H (Qty 2) P/N 7638
20 FT. cord reel for non-hazardous carts P/N 7639

FIXTURE OPTIONS
INS: Inspection with tempered, striped lens (lamps included)
H: Class I & II Div. 2 Industrial with tempered lens (lamps included)
I: Task/Open industrial with polycarbonate lens (lamps included)

REPLACEMENT PARTS
Polycarbonate replacement Lens P/N 7756
F32-T-8 Lamp, 5000K - (Recommended)

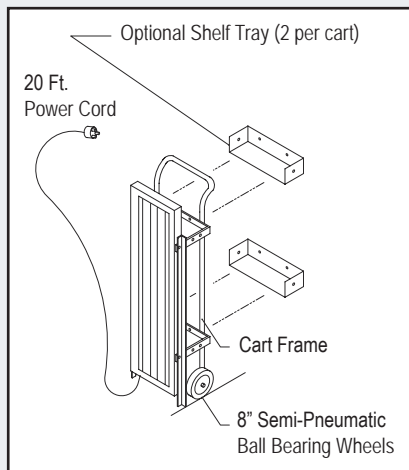

SERIES	FIXTURE	VOLTAGE
4346: LIGHT CART 20' power cord (Specify voltage)	INS: Inspection (Tempered, striped glass) H: Hazardous location (Class I and II, Div. 2) I: Open industrial (UL 1598)	120: 120V standard 277: 277V optional* *277 voltage not available for hazardous locations

TASK / INSPECTION / HAZARDOUS



CART SERIES

TASK / INSPECTION / HAZARDOUS

DATE: _____ PROJECT MGR: _____

JOB: _____

PN: _____



Vertical Mount



Horizontal Mount 2 Fixture Only

Shown with optional tool tray

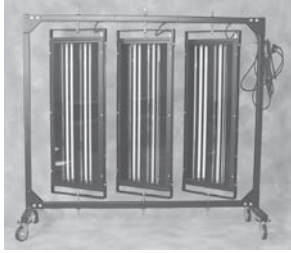

3 Fixture Inspection Cart



Standard 10" Pneumatic Tires

APPLICATIONS

General Industrial
Portable Inspection Areas

The 4 Ft. 2 and 3 fixture light carts are designed to provide portable lighting solutions for applications ranging from inspection to laboratory and general industrial task lighting. A 4 Ft. single fixture horizontal mount cart is also available for all fixture types. Fixtures are attached with swivel mounting brackets allowing for directional aiming of the light (Hazardous location fixtures are stationary mounted). **ASSEMBLY REQUIRED.** Black finish with standard 10" pneumatic tires. (2) swivel (2) non-swivel. Standard 25' power cord with a 3 prong 120 Volt 15 amp plug. Optional 277 Volt 15 amp plug available. Must specify.

SPECIFICATIONS

FIXTURE LISTINGS: ETL listed. U.S. and Canada
INS: Inspection
H: Class I and II Division 2
I: UL 1598 ONLY



ELECTRICAL: Voltage: 120 volts or 277 volts
Amperage: 15 amps standard
Hazardous location carts 120 volts only

OPTIONS: Vertical or horizontal fixture mount (1 or 2 fixture carts only)
Outlet box with 1 duplex outlet available for non-hazardous 120 volt carts P/N 7641
Tool tray with adjustable shelves P/N 7640
NEMA rated power cord plug, other than specified, can be provided.

FIXTURE OPTIONS: INS: Inspection with tempered, striped lens (lamps included) (vertical mount recommended)
H: Class I & II Div. 2 industrial (lamps included)
I: Task/open industrial (lamps included)

REPLACEMENT PARTS
Polycarbonate lens
F32-T-8 lamp, 5000K - (recommended)

SERIES

3668: 2 Fix. Cart
3668H: 2 Fix. Haz. Loc. Cart
3669: 3 Fix. Cart
3669H: 3 Fix. Haz. Loc. Cart
4520: 1-4 Ft. Horizontal Cart

WHEELS

P: 10" Tires
Pneumatic (Std)

FIXTURE

INS: Inspection (Tempered, striped glass)
H: Hazardous Location (Class I and II, Div. 2)
I: Open Industrial (UL 1598)

VOLTAGE

120: 120V Standard
277: 277V optional*
*277 Voltage not available for hazardous locations

NOTES:

P/N 3668H and 3669H are Class I Div. 2 hazardous location carts. These carts are assembled with a stationary fixture mounting bracket.

P/N 3669 and 3669H 3 Fixture carts: vertical mounting position ONLY.

P/N 3668H: Must specify vertical or horizontal mounting.

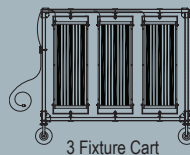

3 Fixture Cart
Vertical Mount ONLY

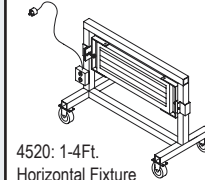
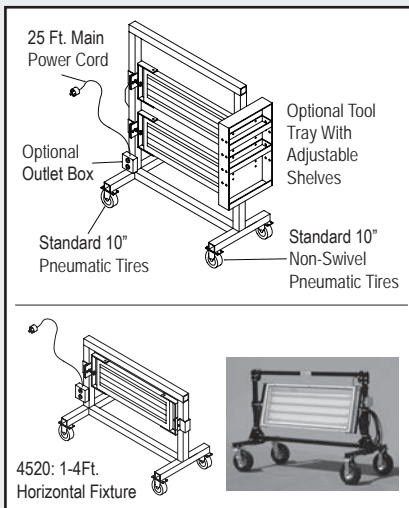

4520: 1-4 Ft.
Horizontal Fixture



TASK / INSPECTION / HAZARDOUS

