

# 383 SERIES



Pendant Mount



Ceiling Mount



Bracket Mount

## EXPLOSION PROOF INCANDESCENT LIGHTING

- UL listed for U.S.
- Explosion proof incandescent fixture for hazardous locations
- Cast aluminum construction with epoxy powder coat finish
- Heat and impact resistant prismatic glass globe
- Corrosion resistant
- Available in 120 volt
- Easy relamping with a single thumb screw



## APPLICATIONS

Paint Spray Booths  
Wet/Damp Locations  
Marine Locations  
Indoor & Outdoor  
Corrosive Areas



[www.ldpi-inc.com](http://www.ldpi-inc.com)



# Bright Ideas Innovative Solutions



The 383 Series is a fixture designed for Explosion-Proof and Hazardous environments. The cast aluminum housing is completed with a heat and impact resistant globe. This product handles incandescent sources up to 300 watts but is limited to 75 watts in paint spray booth applications and features a single thumb screw for easy re-lamping. This product has multiple listings from UL and is UL844 listed. Lamp not included.

## 383 SERIES DIMENSIONS

383 Pendant Mount

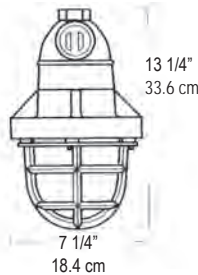

383 Ceiling Mount  
Comes standard with 4 Hole Box

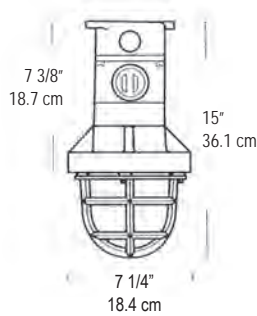

383 Bracket Mount  
Comes standard with 4 Hole Box

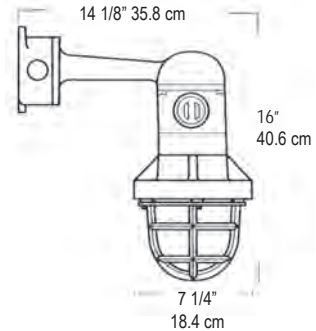

DIMENSIONS (Nominal)

## OPTIONAL REFLECTORS

Standard dome reflector

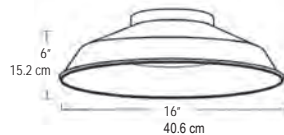

Direct light down with a dome reflector.  
Highly reflective finish over heavy gauge aluminum base.  
Field installation with 4 screws. **Does not fit bracket mount.**

Angle reflector

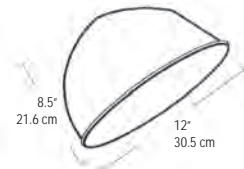

Direct light down and to the side with a 30° angle reflector.  
Highly reflective white epoxy finish over heavy gauge aluminum base.  
Field installation with 4 screws.



www.ldpi-inc.com  
sales@ldpi-inc.com  
1-800-854-0021  
(F) 715-839-8145