



240 8 Ft.

WET / DAMP LIGHTING

Industrial/Machining Areas • Tunnels • Pulp/Paper • Food/Beverage • Prep, Inspection, Sanding

The 240 8 Ft. Series is a very versatile fixture that is ETL listed for ordinary locations. It is an ideal fixture for industrial applications, wet locations and task lighting. Optional adjustable Mounting brackets allow for precise aiming in multiple angles suitable for most applications. The 240 8 Ft. Series is available in 2, 3, 4, 5, 6, 8, 10 and 12 lamp options, all using a 3/16" tempered glass lens with acrylic and polycarbonate optional lenses. With multiple hub locations, the 240 8 Ft. Series can meet most of your wiring needs. Lamps not included.

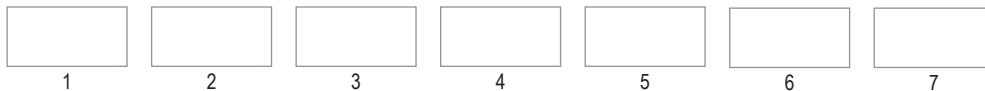

1 SERIES	2 LAMP TYPE	3 LAMP QUANTITY	4 LENGTH	5 VOLTAGE	6 HUB
240	T5: (4') 28W T5HO: (4') 54W T8: (4') 32W, (8') 59W T8HO: (4') 44W, (8') 86W	2L: 2 Lamp 3L: 3 Lamp 4L: 4 Lamp 5L: 5 Lamp 6L: 6 Lamp 8L: 8 Lamp** 10L: 10 Lamp** 12L: 12 Lamp**	8: 8 Ft.	UNV1: 120-277V UNV2: 347-480V*** 347: 347V	TS: Top and Side Hubs†

7 OPTIONS
AM: Adjustable Angle Mounting Brackets (PN: 9349)◆ CB: Cable Mount (PN: 6875) Includes 5 ft. Cables Std. WH: 8' Wire Whip SR: Specular High Bay Reflector W: Wire Guard F: Fuse A: Acrylic Lens P: Polycarbonate Lens EM: Battery/Driver Backup (90 Min.) 8HLO: High Light Output Ballast (T8 32W Lamp Only) 8FTL: 8 Ft. Lamp****

NOTES:

- ** 4' lamps only
- *** UNV2 T5HO Only
- **** Fixture comes equipped with 4 Ft. lamps. Select 8FTL for optional 8 Ft. Lamps
- † 1/2" NPT standard
- ◆ For horizontal or ceiling mounted fixture only

LISTINGS

UL 1598 Wet / Damp
 CSA 22.2 No. 250.0
 25° C Ambient Rating

FEATURES

Front access fixture
 Hinged front door frame
 Hinged ballast tray
 Sturdy 18 Ga. steel white powder coated housing
 Spring loaded lamp holders - standard
 3/16" tempered glass lens
 Zinc latches

ELECTRICAL

Available in: T5 28W, T5HO 54W, T8 32W and 59W, T8HO 44W, and 86W
 Voltages of 120, 277, 347 and 480
 Through feed wiring

OPTIONS

Adjustable surface mount brackets
 Cable mount
 Chain mount kit
 8' wire whip
 Specular reflector
 Wire guard
 Fusing (not listed for Canada)
 Acrylic lens
 Polycarbonate lens
 EM: UL924 Emergency battery backup ballast
 HLO (high light output) ballast for T8 32 watt lamp only
 Mounting Kits - ordered separately

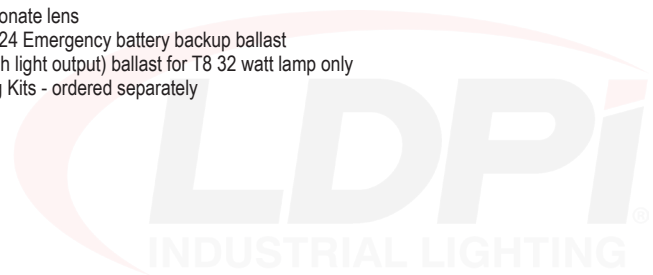

240 8 Ft.

WET / DAMP LIGHTING

Industrial/Machining Areas • Tunnels • Pulp/Paper • Food/Beverage • Prep, Inspection, Sanding

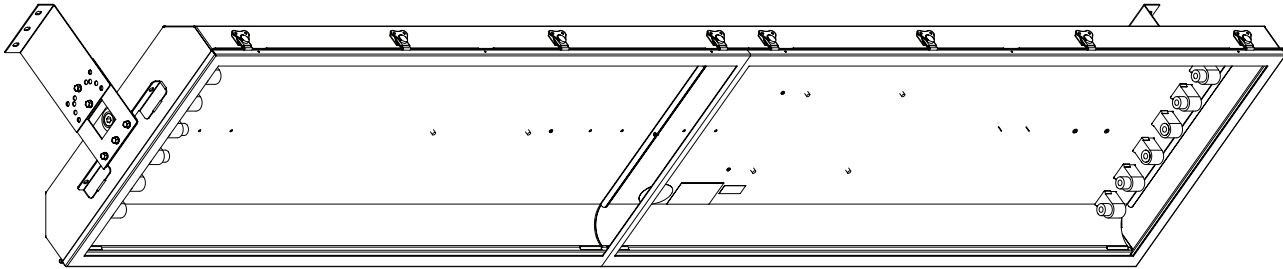

DIMENSIONS

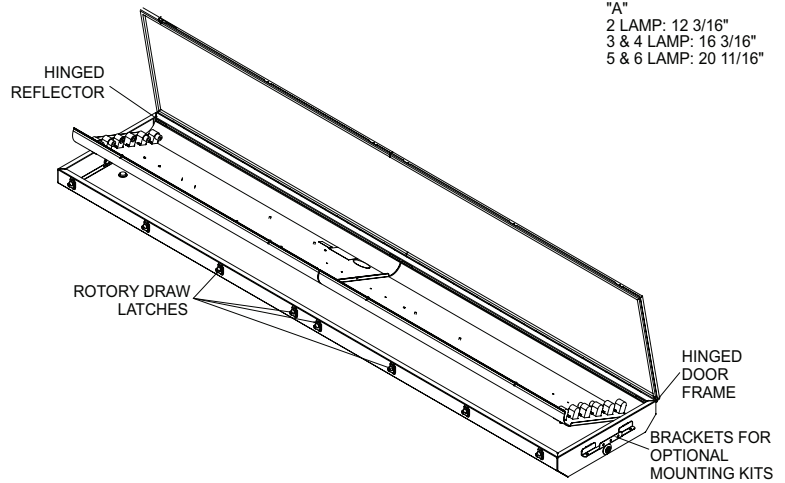
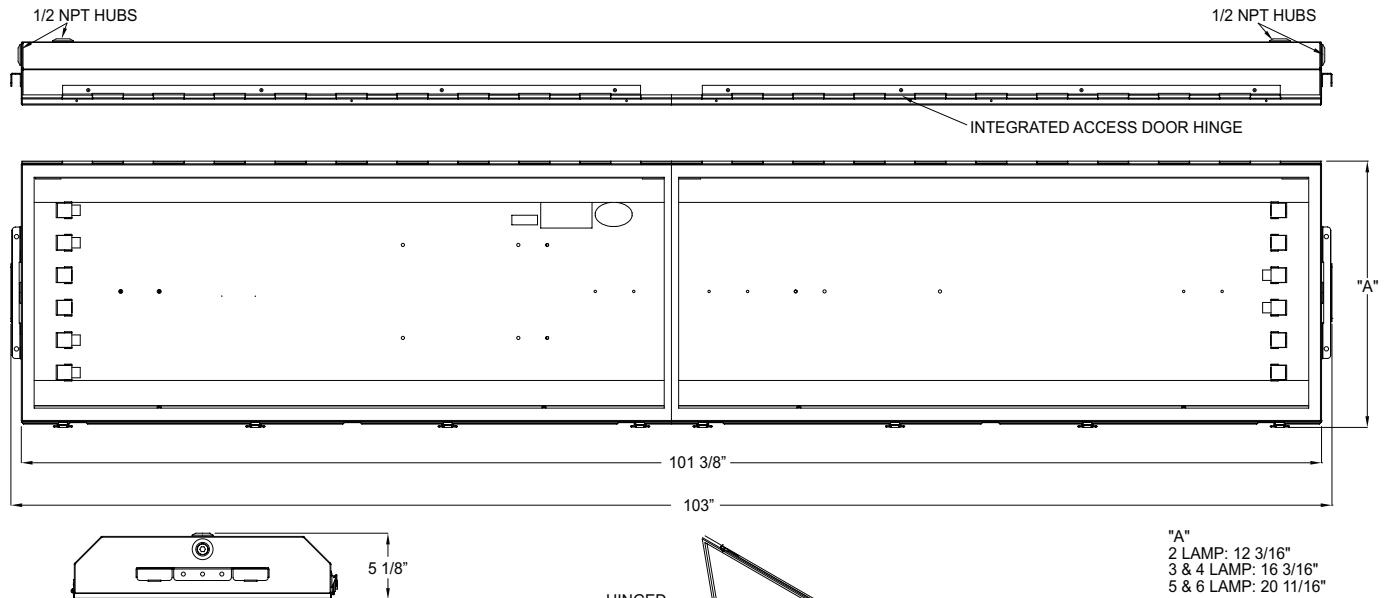



240 8 Ft.

WET / DAMP LIGHTING

Industrial/Machining Areas • Tunnels • Pulp/Paper • Food/Beverage • Prep, Inspection, Sanding

MOUNTING

NOTE: Mounting kits shown on shorter 4 Ft. fixture for clarity

Chain Hang Kit
Part Number: (9350)

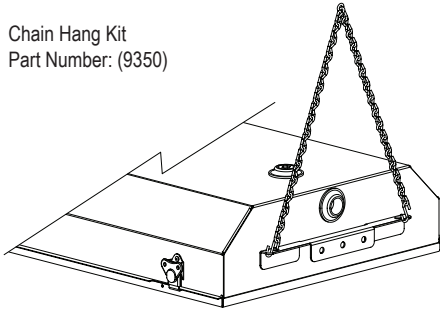

Cable Hang Kit
Part Number: (6875 zinc coated)
and (6875SS stainless steel)
QTY 2 cables with toggle ends
and QTY 2 self locking gripples

102" between cables

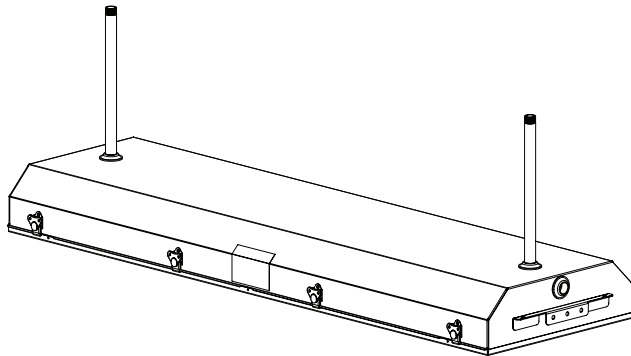
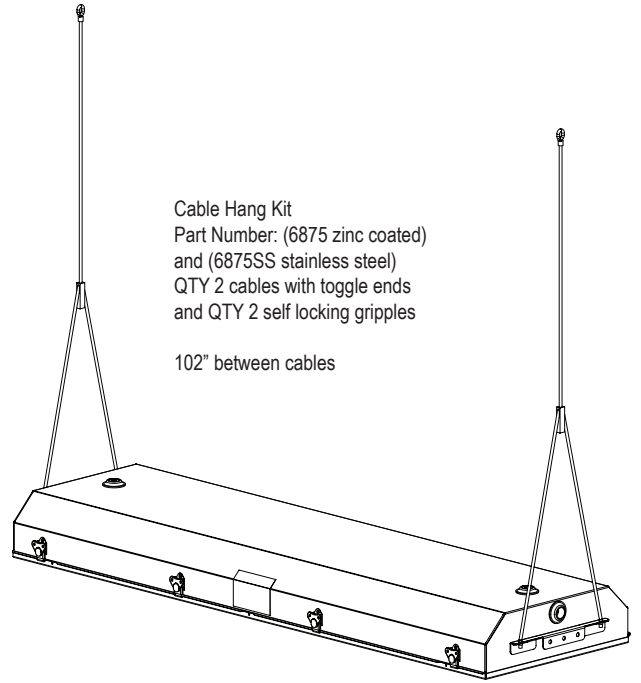

Pendant Style Mounting
NOTE: Conduit provided by others

Fixture suspended with 1/2" electrical conduit
using top hubs on fixture at both ends.

94 7/8" between conduit

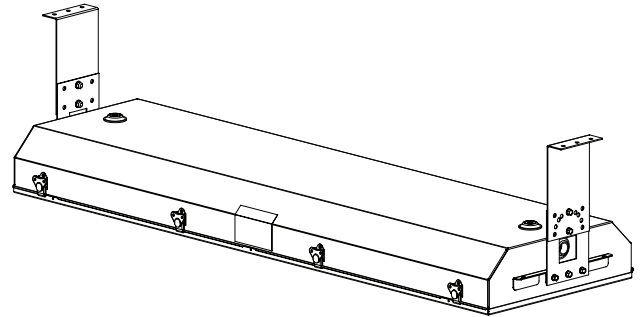

Adjustable Surface Mounting Bracket Kit
Part Number: (9349 galvanized)
and (9349SS stainless steel)
Bracket attachment point for optional mounting methods

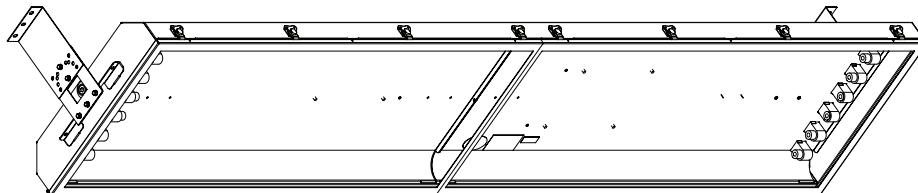

8 Ft. 6 lamp shown with Adjustable Surface Mounting Bracket kit

THERE ARE A NUMBER OF MOUNTING METHODS THAT ARE NOT SHOWN.