



INSTALLATION, OPERATION AND MAINTENANCE INSTRUCTIONS

240 8 Ft. FRONT ACCESS FLUORESCENT LIGHTING FIXTURES

WARNING!

1. TO PREVENT THE RISK OF ELECTRICAL SHOCK DEACTIVATE/DISCONNECT THE POWER SUPPLY BEFORE INSTALLING OR RELAMPING FIXTURE.
2. THIS FIXTURE SHOULD BE INSTALLED BY QUALIFIED TECHNICIANS IN STRICT ACCORDANCE WITH THE NATIONAL ELECTRICAL CODE AND ANY LOCAL REQUIREMENTS.

1. Before installing, make sure that the circuit is deactivated.
2. This unit is completely assembled. Before installing, check the fixture label to insure correct voltage and frequency.
3. The ballast in this fixture is designed to operate on grounded neutral systems only.
4. Typical 240 Series fixture installations are shown on page 2.
5. Wire fixture through hub(s) and install ½" plug(s) on unused conduit hub(s).
Note: Lubricate all threads with petrolatum.

TYPICAL 240 INSTALLATIONS

PENDANT STYLE MOUNTING

CONDUIT PROVIDED BY OTHERS

Fixture suspended with 1/2" electrical conduit using top hubs on fixture at both ends.

NOTE:

Lubricate all threads with petrolatum

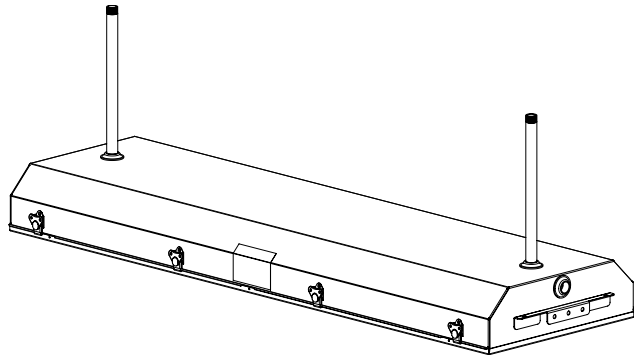

CABLE HANG KIT

PART NUMBER: (6875 ZINC COATED)

QTY 2 CABLES WITH TOGGLE ENDS

AND QTY 2 SELF LOCKING GRIPPLES

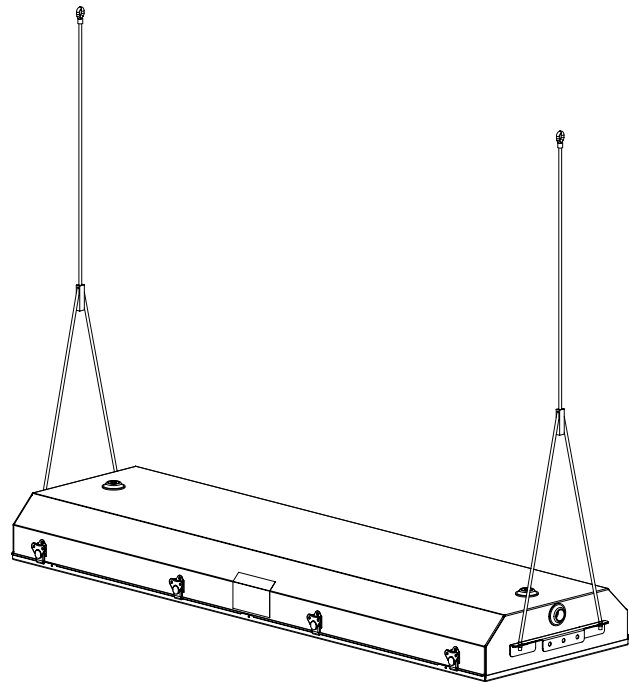

ADJUSTABLE SURFACE MOUNTING BRACKET KIT

PART NUMBER: (9349 GALVANIZED)

BRACKET ATTACHMENT POINT FOR OPTIONAL MOUNTING METHODS.

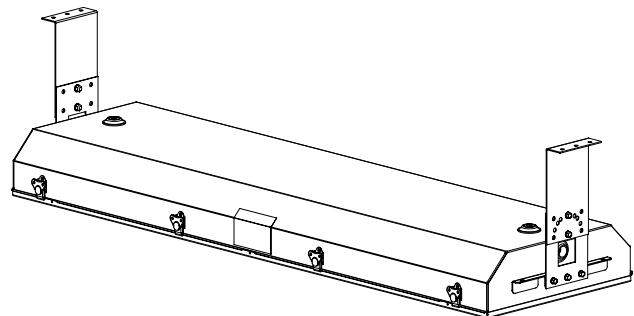

THERE IS A NUMBER OF MOUNTING METHODS THAT ARE NOT SHOWN.

MAINTENANCE DATA

1. Although no routine maintenance is required to keep this fixture functional, it should be checked periodically to ensure that it is working properly and to look for any external damage.
2. For optimum performance, keep light transmission parts of fixture clean. Any commercial glass cleaner can be used to clean the glass.
3. To Relamp: disconnect supply circuit. Lift and turn each latch handle. Move each slide catch from glass frame keeper. The glass frame will swing open. Replace old lamp with new lamp. Close glass frame. Move each slide catch over glass frame keeper. Turn and push down each latch handle to seal glass frame.
4. In the event of glass breakage, it will be necessary to replace the damaged glass frame assy, in order to maintain the integrity of the fixture.

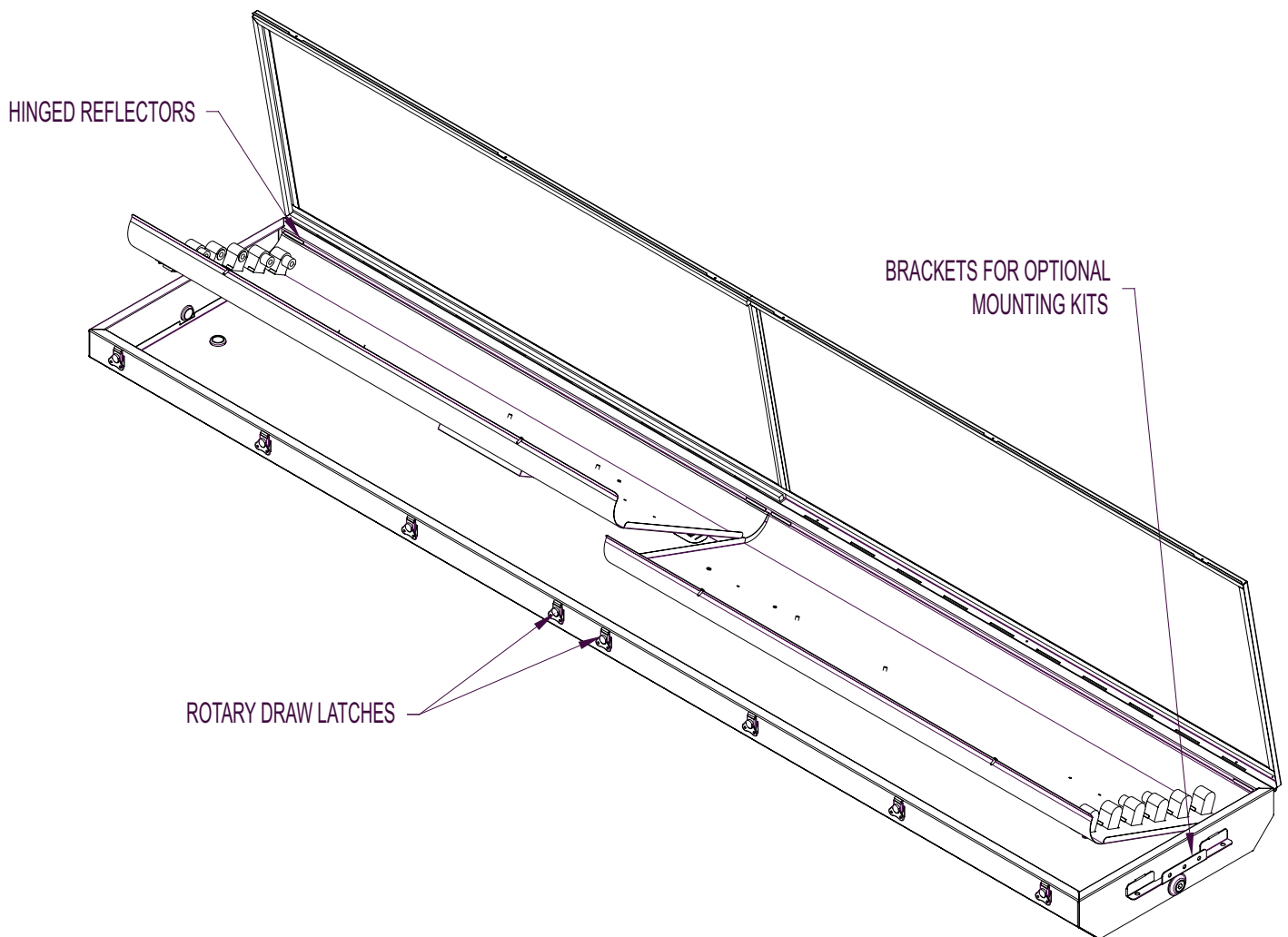

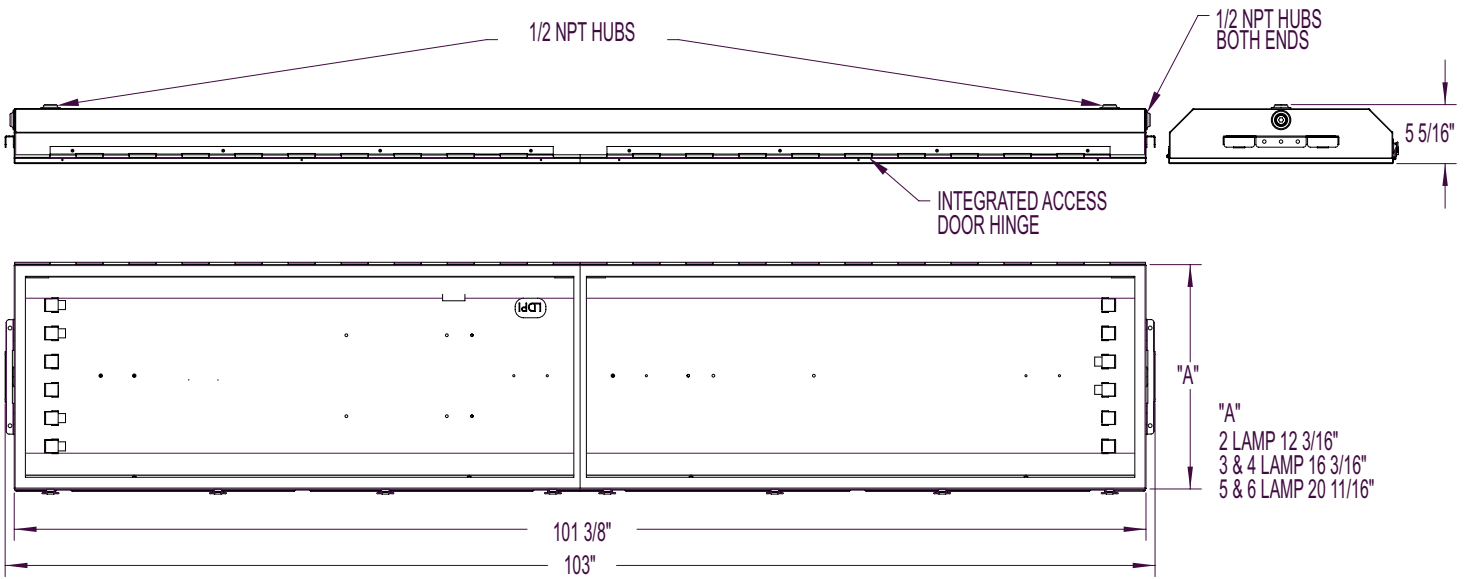

LDPI, Inc.
 Eau Claire, WI 54703
 TOLL FREE
 1-800-854-0021
 Web: www.ldpi-inc.com
 E-mail: sales@ldpi-inc.com